



## Barriers MAGSTOP (toll road barriers)

MIB 10 / MIB 20

Technical data:	Unit	MIB 10	MIB 20
Maximum boom length	mm	2500	2500
Aluminium octagonal profile	100 x 55 x 1.6 mm	3000	3000
Aluminium round profile	Ø 75 x 1.4 mm	adjustable 0.6 – 3.0	0.9
Opening and closing times	s	230/115	230/115
Voltage	V	50 – 60	50 – 60
Frequency	Hz	400	240
Power consumption	max. W	350	350
Housing: width	mm	350	350
Depth	mm	1010	1010
Height	mm	50	50
Weight not including barrier boom	kg	DC motor	Torque motor
Drive			

### Technical Description

The combination of our proven and reliable electric motor with a lever system represents a simple and extremely reliable drive solution. It permits short opening and closing durations without the barrier boom bouncing in the end positions. The lever system locks the barrier boom at both end positions. In the event of a power failure, it can still be moved easily by hand.

The complete drive system is attached to the barrier housing as a single unit, and can easily be removed from the housing by removing the mounting screws.

A built-in spring mechanism provides a precise counterbalance for the barrier boom. The springs are factory set to correspond with the boom length prior to delivery. If necessary, the springs can be easily reset in situ during assembly, for example if the barrier boom is shortened or if signs are attached to the boom.

It is also a simple matter to change the handing on-site from right-axial to left-axial.

### The Drive Unit

The two barriers MIB 10 and MIB 20 differ in the type of motor drive they are fitted with. In the end positions, the motor remains with voltage applied but at reduced power. This power is dissipated in the form of heat, which prevents the occurrence of condensation and corrosion. This guarantees consistent opening and closing times, even in cold climatic conditions.

### MIB 10

The heart of the barrier is the combination of the brushless maintenance free direct current motor with its intelligent control mechanism. This combination, developed especially for this application, represents a substantial technological leap forward due to its flexible acceleration and deceleration and its independently adjustable opening and closing times. This further optimises the movements achieving considerable service life with long maintenance-free intervals.

Hall sensors integrated into the motor provide precise data regarding the position of the barrier boom at any particular instant, and they also provide the control system with a way of verifying the optimum acceleration and braking characteristics.

By calculating the exact position of the boom, it is possible to make feedback directly available in any position in the form of zero potential signals. This removes the need for mechanical limit switches which are prone to wear and tear.

### MIB 20

The heart of this barrier is the special AC torque motor. The features of this motor are its long service life, freedom from maintenance, and the fact that it is possible to stall it in any position without risk of damage. Imprecise friction clutches and limit switches are not necessary. The position sensor sends precise

data concerning the position of the barrier boom to the control unit. The optimum brake position of the barrier boom is always guaranteed as a result of the control mechanism developed by Magnetic. The control mechanism is equipped with self-learning software which prevents any subsequent bounce of the barrier boom. The barrier is factory wired and ready to connect, tested and supplied with mounting accessories.

### The Housing

The housing is manufactured from 2 mm zinc plated sheet steel on to a base frame of stainless steel, then phosphate and powder coat finished for maximum protection against corrosion.

Control units are mounted onto a removable zinc plated sheet steel panel. All of the components within the barrier housing are readily accessible through the maintenance door and removable top cover. The housing is supplied in an RAL 2000 orange colour finish as standard. Other colours are available on request, at extra cost.

### Available Versions

Barriers may be supplied with the barrier boom fitted to either the right or left hand side. In its standard configuration the maintenance access door is positioned at the rear, although on request it can be any one of the other sides.

### The Round Barrier Boom MSB 4

The round boom is made of highly stable aluminium  $\varnothing$  74 mm x 1.4 mm profile, and finished with an RAL 9010 white powder coat then applied with bright red reflective tape strips.

### The Octagonal Barrier Boom MSB 5

This boom is extruded from highly stable aluminium alloy to produce an octagonal profile of 100 mm x 55 mm x 1.6 mm and finished with an RAL 9010 white powder coat then applied with bright red reflective tape strips.

### The Control Device

Both the MIB 10 and MIB 20 barriers may only be operated in conjunction with the respective MLC controllers especially developed by Magnetic. Refer to the applicable MF data sheets for relevant details in each case.

### Safety

The following safety instructions are to be observed for installation and operation of the barriers:

1. The foundation must be produced in accordance with Magnetic data sheet MF 5115.
2. The minimum required distance between the end of the barrier boom and the nearest building (or wall etc.) is 500 mm.
3. It is forbidden for persons or goods to be anywhere within the swing zone of the barrier boom while it is in operation.
4. The closing and opening actions must be observed. The mounting of operating elements outside the field of view is not permissible; there must be a line of visibility between the barrier and the control system.
6. The barrier boom fixture can withstand winds of up to a maximum of force 10 on the Beaufort scale ( $\approx 500 \text{ N/m}^2$ ).

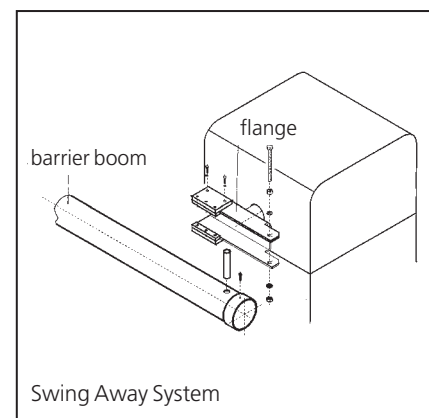
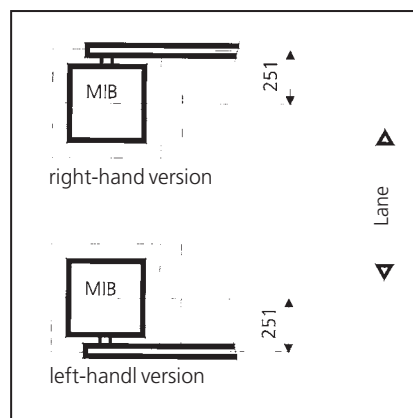
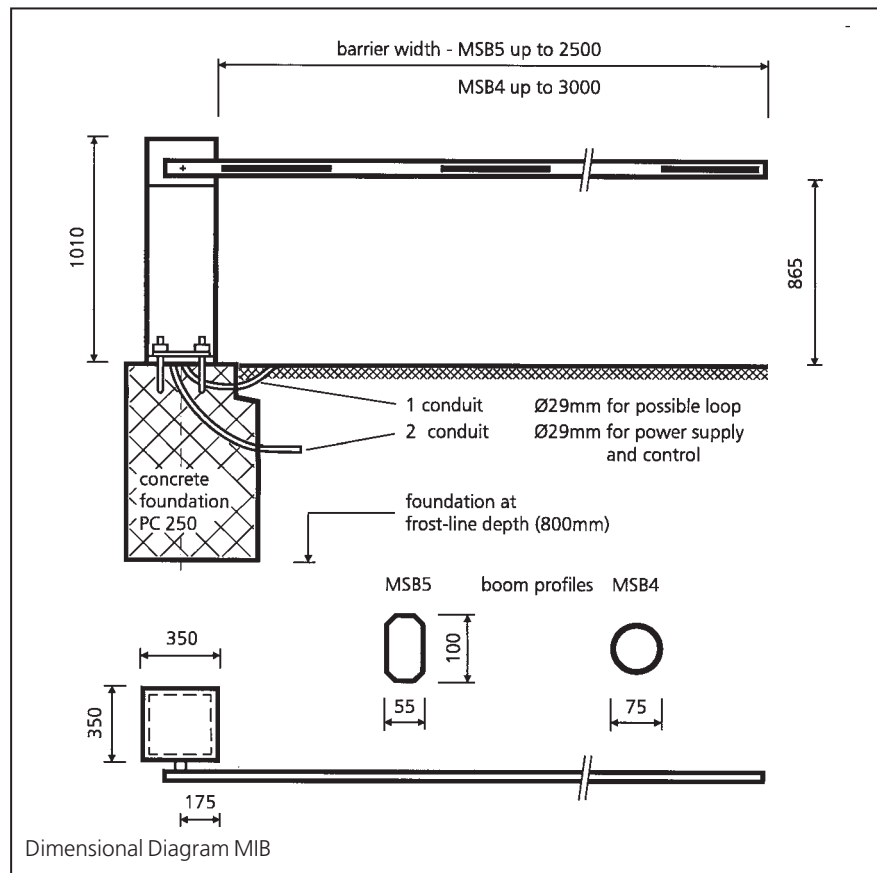

### The Electrical Connection

Electrical connections are carried out in accordance with factory circuit diagrams. Our control devices may necessitate the application of special connection diagrams for certain configurations. This can be supplied by us on request.