



## Barriers MAGSTOP Eco Barrier

### MBE 35 / MBE 50

Technical Data	Unit
Max. boom length	mm
Opening time	s
Closing time	s
Voltage	V
Frequency	Hz
Power consumption	W
Housing width	mm
Depth	mm
Height	mm
Weight	kg

	MBE 35	MBE 50
Max. boom length	3500	5000
Opening time	approx. 3.0	approx. 6.3
Closing time	approx. 3.6	approx. 7.5
Voltage	230	230
Frequency	50	50
Power consumption	85	85
Housing width	300	300
Depth	350	350
Height	1040	1040
Weight	50	50

#### The Barrier

The ECOLINE barrier represents the combination of our proven Magnetic technology with the 1-phase torque motor, a simple housing and a conventional control for both manual and automatic operation. Further remarkable features of the ECOLINE barrier are a simple assembly and starting.

These barriers are suitable for all applications with simple requirements, e.g. private residential entries, smaller car parks or those controlled by a guard.

The base control unit and a limit switch are integrated in the barrier. The barrier booms may be supplied in either standard or customized length.

#### The Drive Unit

The reliable direct drive consists of the maintenance-free torque motor, the lever system which enables an harmonious movement of the barrier boom without bouncing and the counterbalance springs for balancing the boom weight. Via the lever system the barrier boom is locked in both end positions open and close, however, in case of power failure the barrier can easily be opened manually. This can be done without opening the barrier and even without using any tools.

The precise spring adjustment to correspond to the boom length can be done quickly at site. This may be necessary, e.g., if the barrier boom is shortened or if signs are attached. An automatic opening of the barrier boom in case of power failure can be achieved by a stronger adjustment of the springs. In the end positions the motor remains under power and the low power consumption of the motor is dissipated in the form of heat which guarantees the barrier to be operated

at low temperatures and also prevents the occurrence of condensation in the motor and housing.

#### The Housing

The barrier consists of a self-supporting and compact housing with a UV-resistant and environmental-friendly powder coat finish for maximum protection against corrosion. The housing is supplied in a RAL 2000 orange colour (yellow orange) finish as standard; the hood in RAL 9006 (white aluminium). Other colours are available on request, at extra cost. The control unit and the all-pole isolating switch are mounted onto the mounting plate. Pre-mounted top hat rails enable a simple installation of further electrical devices. The mounting plate and the drive unit within the barrier housing are readily accessible through the maintenance door at the left hand side. After unlocking by key the top cover can also easily be removed.

#### The barrier boom

The barrier boom is extruded from highly stable aluminium alloy to produce an octagonal profile of 100 mm x 55 mm x 1.6 mm and finished with a RAL 9010 white powder coat then applied with bright red reflective tape strips. Hence the boom is readily visible even at night. If the barrier is to be any longer than 3.5 metres, it is absolutely necessary to fit either a pendulum support or a fixed support post.

If the available vertical height is restricted the barrier can be supplied with an articulated boom at extra cost.

#### The Control Unit

The ECOLINE control unit with microcontroller technology enables the barrier to be operated manually or automatically. There are 11 standard functions to be selected. The barrier either closes by the manual pulse command CLOSE, automatically after passage or in dependence on the connected safety equipment.

The connection of additional safety equipment for pedestrians is possible.

Besides the standard operating modes several special functions are additionally integrated. These enable the drive of warning lights and signal lamps. The storage of the activated opening pulses makes possible an automatic operation, i.e. the barrier remains open until all vehicles have passed. In case of power failure can be selected if the barrier shall start either after a manual reset, a signal reset or automatically. For safety reasons the manual reset function is factory-set. This means the barrier remains open as long as the reset button at the control unit is pressed manually. The electrical connection is carried out via the big and clear terminals for mains supply and control power. The motor is driven abrasion-free via TRIAC output stage. All signal inputs and relay outputs are opto-decoupled. Simple adjustment of the operating mode and selection of the special functions by means of a rotary switch and DIP-switch.

For the power supply of external devices, e.g. induction loop detectors 24 V DC / 0.5 A will be supplied.

LED indications show the active status of inputs and outputs. This makes easy the operation and error diagnosis.

For manual operation of the barrier a control panel with additional switch „permanent open“ and LED indications can be connected.

### The Signal Inputs

The 6 signal inputs (24 V DC) fulfil the following functions:

- Input 1 = Opening
- Input 2 = Opening loop detector
- Input 3 = Closing
- Input 4 = Pedestrian safety
- Input 5 = Safety
- Input 6 = Limit switch

### The Relay Outputs

The 4 potential-free relay outputs can be loaded with max. 1.0 A / 24 V DC . The required functions can be selected via DIP-switch.

- Output 1= motor drive direction or feedback CLOSE
- Output 2 = pulse if barrier opens or pulse after release of the safety device (passage)
- Output 3 = Drive of warning light or signal lamp
- Output 4 = Common failure signalling or traffic light control

### Mounting, Installation and Connection

All electrical installation works have to be done only by authorized trained specialists. The delivery contains the mounting material and the fixing kit for the barrier boom.

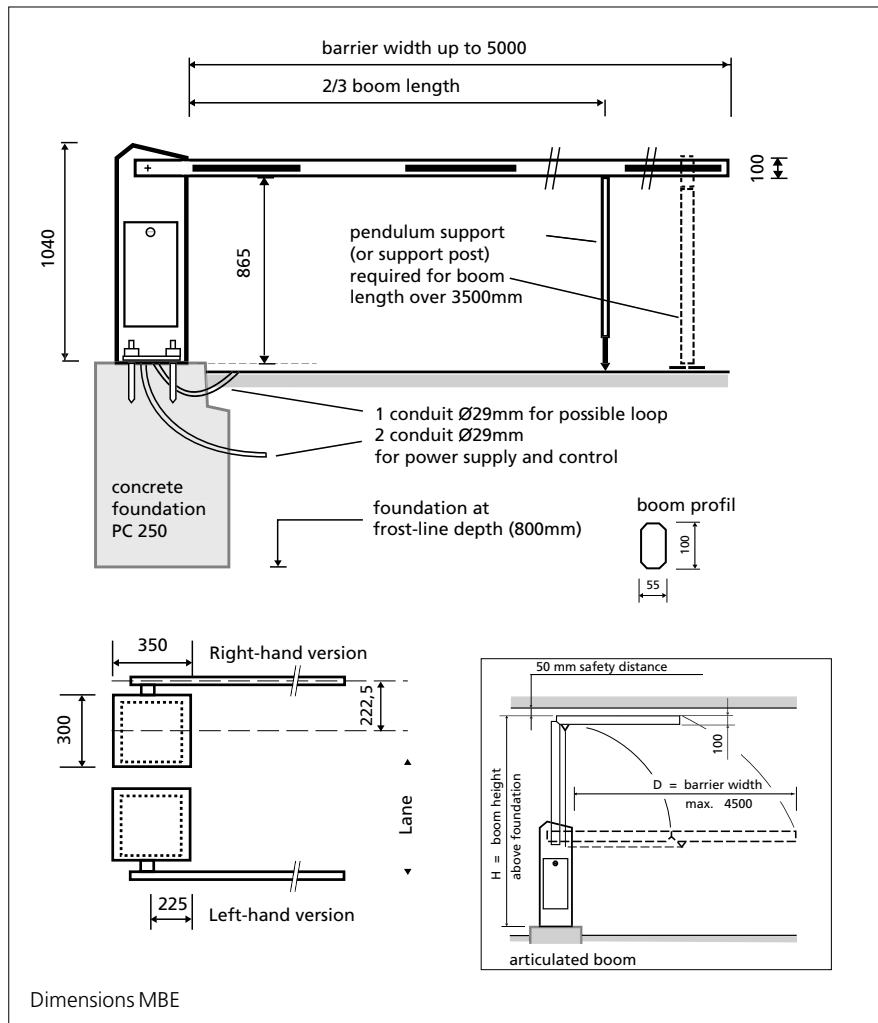

### Safety

The details for the mounting and operating instructions as well as the country-specific accident prevention regulations are to be observed for installing and operating the barriers.

MAGNETIC emphasizes that the barriers may only be used to control vehicle traffic.

The operator has to ensure an absolute separation of vehicle and passenger traffic by taking appropriate measures. For constructional measures, like walkways beside the roadway, for example, additional markings and information signs have to be applied.

The delivery of Magnetic contains two pictographs „Forbidden for pedestrians“. The opening and closing actions must be observed. The operating of the barrier outside the field of view and without safety devices is not permissible.

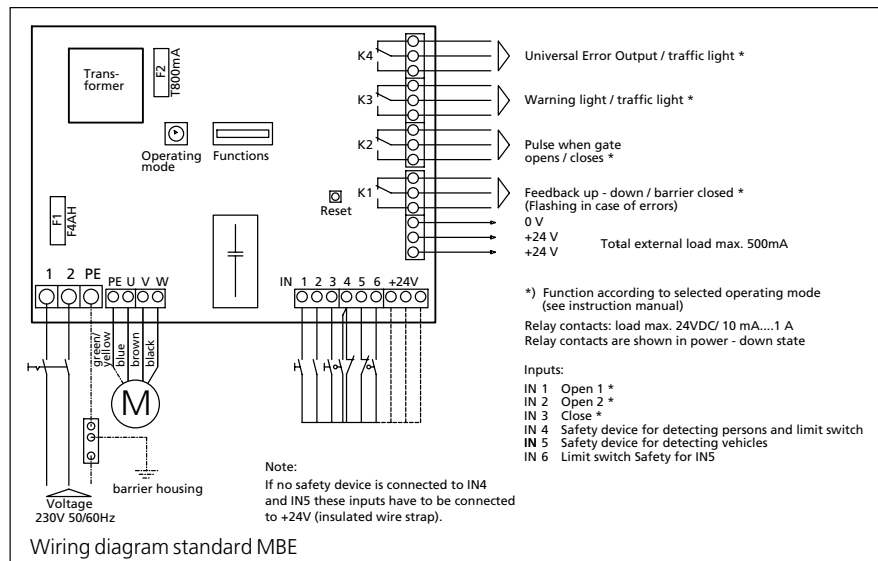

Magnetic products correspond to the quality assurance according to the ISO 9001 regulations.

### Order details

- Type:  MBE35  MBE50  
 Version:  Right  Left  
 Required width "D" = \_\_\_\_\_ mm  
 Order quantity \_\_\_\_\_ pcs

- For boom length > 3500 mm  
 Pendulum support  support post  
 Articulated boom necessary?  Yes  
 If yes, "H" = \_\_\_\_\_ mm